



### M PROGRAMMER

New M programmer: push buttons to control temperature and time



### OUTSTANDING FEATURES

Reversing drum action as standard  
Stainless steel drum as standard  
Frequency inverter as standard



### EFFICIENCY

DOUBLE FLOW - mixed axial-radial airflow  
Big fluff filter



### VERSATILITY

Make to order - customisation  
OPL > Multivending - Standard OPL model easily transformable to coin laundry uses



### ERGONOMICS

Drawer as fluff filter, stainless steel mesh  
Biggest door diameters



### MAINTENANCE

Hinged control panel: easy and ergonomic access  
Technical menu: statistics for technicians and maintenance with external console (with console option)



### OTHERS

Grey skinplate outer casing, stainless steel look  
SFEX - Integrated Fire Extinguishing System  
SOFT DRY - new drum with stamped holes  
COOL DOWN - anti-wrinkle at the end of the cycle  
Heating options: electric, gas  
CE approved



### OPTIONS

- Screen in M programmer (2 units)



- Double doorglass
- Fluff filter with grid 0,3 mm (standard in STACK is 0,6 mm)
- Stainless steel front and side panels
- Front panel in stainless steel
- Maritime wooden packing
- Ship voltage for electric models: 440V III 50/60 Hz No neutral
- Other voltages available

TECHNICAL DATA	UNIT.	DTM2-22
<b>CAPACITY</b>		
Capacity 1/18	Kg	48
Capacity 1/20	Kg	44
Hourly Output (gas)	Kg/h	88
Evaporation capacity (gas)	l/h	44
<b>DRUM</b>		
Ø Drum	mm	835
Ø Door	mm	574
Door center height	mm	547 / 1.618
Load hole bottom height	mm	272 / 1.322
Drum length	mm	800
Drum volume	l	438
<b>POWER</b>		
Drum motor power	kW	0,37 x 2
Fan motor power	kW	0,55 x 2
Electric heating power	kW	-
Total electric power (elec.model)	kW	-
Gas heating power	kW	30,4 x 2
Instant propane gas consumption (G31)	kg/h	1,03 x 2
Instant natural gas consumption (G20)	m3/h	1,27 x 2
Total electric power (gas model)	kW	1,94
<b>CONNECTIONS</b>		
		<b>GAS</b>
Tension 230V - I + N + T	Nº x mm2 / A	3 x 1,5 / 20A
Tension 230V - III + T	Nº x mm2 / A	-
Tension 400V - III + N + T	Nº x mm2 / A	-
Ø Gas inlet	BSP	3/4"
<b>DIMENSIONS / PACKING DIMENSIONS</b>		
Net width / Gross width	mm	870 / 950
Net Depth / Gross Depth	mm	1.328 / 1.411
Net Height / Gross Height	mm	2.117 / 2.250
Net weight / Gross weight	Kg	374 / 394
<b>OTHERS</b>		
Max airflow	m3/h	900 x 2
Ø Fume exhaust	mm	250
Sound level	dB	69

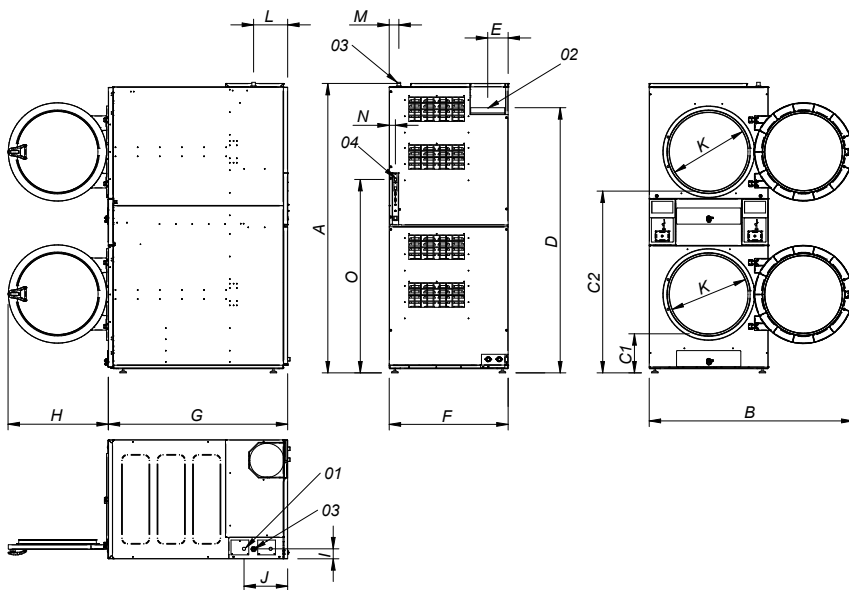

- 01 ELECTRIC CONNECTION
- 02 FUMES OUTLET Ø250
- 03 GAS INLET 3/4
- 04 ETHERNET CONNECTION (only available CONTROL TOUCH II models)

	A	B	C1	C2	D	E	F	G	H	I	J	K	L	M	N	O
DTM2-22	2118*	1490	286	1330	1940	149	870	1312	735	73	320	575	250	70	45	1416

\* Measurement with legs mounted (30mm)