



## TOUCH II

User friendly and totally programmable 7" Touch II  
USB Connection. Online platform free of charge for  
programming, telemetry, data analysis...thanks to  
the IoT  
Videos on display (ads, instructions, etc.)  
37 languages



## OUTSTANDING FEATURES

Reversing drum action as standard  
Stainless steel drum as standard  
Frequency inverter as standard



## EFFICIENCY

EFFICIENT DRY - Intelligent humidity control. With  
new drum inlet temperature control.  
AIR RE-CYCLE - Efficient air recirculation system  
THERMAL INSULATION - Complete air-flow circuit  
Double door glass  
FULL FLOW - New 'optimized' system of mixed  
airflow  
Big fluff filter



## VERSATILITY

Make to order - customisation  
WET CLEANING



## CONNECTIVITY

Standard IoT Domus Connect



## ERGONOMICS

Drawer as fluff filter, stainless steel mesh  
Biggest door diameters  
Opening sense of door adjustable on site



## MAINTENANCE

Hinged control panel: easy and ergonomic access  
Technical menu: statistics for technicians and main-  
tenance with external console (with console option)



## OTHERS

Grey skinplate outer casing, stainless steel look  
SFEX - Integrated Fire Extinguishing System  
SOFT DRY - new drum with stamped holes  
COOL DOWN - anti-wrinkle at the end of the cycle  
Heating options: electric, gas and steam  
CE approved



## OPTIONS

- Opposite door opening
- Tropicalized model
- Dosing/spraying system
- Back panel external air + filter
- Fluff filter with grid 0,6mm (standard is 0,3mm)
- Fluff filter with grid 1,2mm (standard is 0,3mm)
- Stainless steel front and side panels
- Front panel in stainless steel
- Steam battery in stainless steel
- Low pressure steam battery
- Reduced power (12kw instead of 18kw) for DTT-18
- Ship voltage for electric models:  
440V III 50/60 Hz No neutral
- Other voltages available
- Maritime wooden packing

TECHNICAL DATA	UNIT.	DTT-18 ECO-ENERGY		DTT-22 ECO-ENERGY	
<b>CAPACITY</b>					
Capacity 1/18 // Capacity 1/20	Kg	18,3 // 16,5		24,3 // 21,9	
Hourly Output (electr. // gas)	Kg/h	30 // 33,6		40 // 44,6	
Evaporation capacity (electr. // gas)	l/h	14,9 // 16,3		20 // 22,3	
<b>DRUM</b>					
Ø Drum	mm	750		835	
Ø Door	mm	574		574	
Door center height	mm	976		1030	
Load hole bottom height	mm	689		743	
Drum length	mm	746		800	
Drum volume	l	330		438	
<b>POWER</b>					
Drum motor power	kW	0,37		0,37	
Fan motor power	kW	0,55		0,75	
Electric heating power	kW	18		24	
Total electric power (elec.model)	kW	18,97		25,17	
Gas heating power	kW	20,51		31	
Instant propane gas consumption (G31)	kg/h	1,76		2,66	
Instant natural gas consumption (G20)	m3/h	2,17		3,28	
Total electric power (gas model)	kW	0,97		1,17	
Steam heating power	kW	30		49,2	
Total electric power (steam model)	kW	0,97		1,17	
<b>CONNECTIONS</b>					
		<b>ELECTRICAL</b>		<b>GAS/STEAM</b>	
Tension 230V - I + N + T	Nº x mm2 / A	-		3 x 1,5 / 20A	
Tension 230V - III + T	Nº x mm2 / A	4 x 16 / 63A		3 x 1,5 / 20A	
Tension 400V - III + N + T	Nº x mm2 / A	5 x 10 / 32A		3 x 1,5 / 20A	
Ø Gas inlet	BSP	1/2"		1/2"	
<b>DIMENSIONS / PACKING DIMENSIONS</b>					
Net width / Gross width	mm	785 / 865		890 / 970	
Net Depth / Gross Depth	mm	1125 / 1210		1255 / 1345	
Net Height / Gross Height	mm	1694 / 1840		1812 / 1940	
Net weight / Gross weight	Kg	187 / 200		210 / 230	
<b>OTHERS</b>					
Max airflow	m3/h	1200		1.500	
Ø Fume exhaust	mm	200		200	
Sound level	dB	64		65	

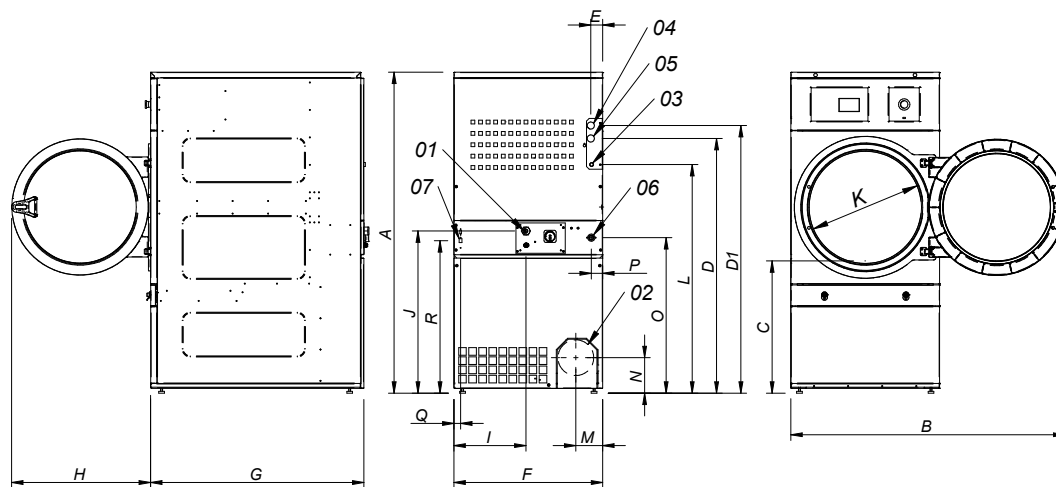

- 01 POWER SUPPLY
- 02 FUMES OUTPUT Ø200
- 03 GAS INLET 1/2"
- 04 STEAM INLET 3/4"
- 04 STEAM INLET 1" (22kg)
- 05 CONDENSATE OUTLET 3/4"
- 05 CONDENSATE OUTLET 1" (22kg)
- 06 SPRINKLER VALVE 3/4"
- 07 ETHERNET CONNECTION

	A	B	C	D	D1	E	E1	F	G	H	I	J	K	L	M	N	O	P	Q	R
DTT-18	1694*	1447	689	1354	1422	68	68	785	1125	735	380	870	575	1226	133	180	830	65	35	805
DTT-22	1812*	1552	743	1430	1532	112	55	890	1255	735	107	920	575	1344	238	180	885	65	37	860

\* Measurement with legs mounted (30mm)